

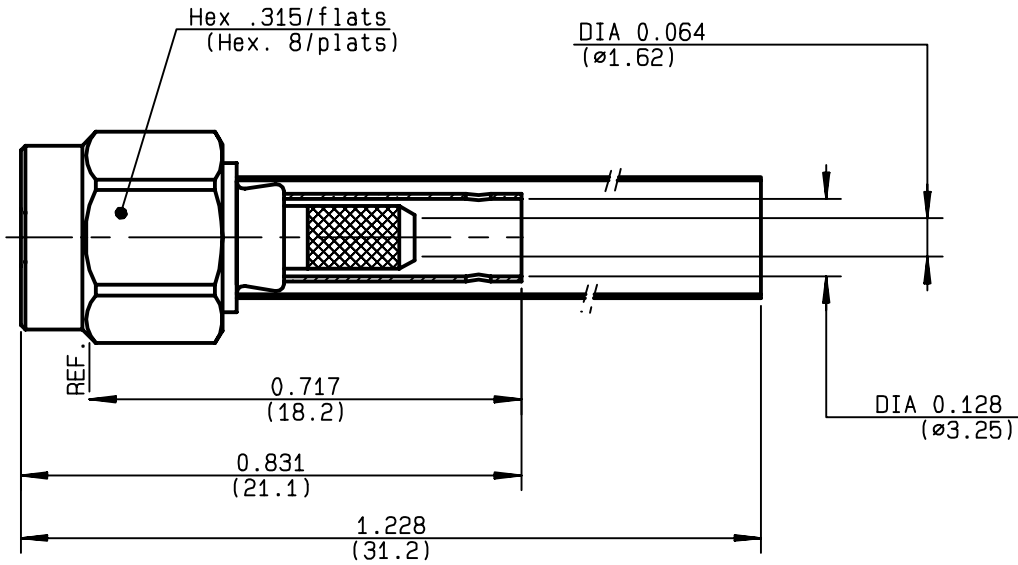

**STRAIGHT PLUG CRIMP TYPE
CABLE 2.6/50D**

R125.072.008
SERIES SMA



NOMINAL IMPEDANCE	50 Ω	CABLES : K02252D RD 316
FREQUENCY RANGE	0-12.4 GHz	
TEMPERATURE RATING	-65/+165 °C	
V.S.W.R	1.15 + .02 x F(GHz)Maxi	
RF INSERTION LOSS	0.06 √F(GHz) dB Maxi	
VOLTAGE RATING	250 Veff Maxi	
DIELECTRIC WITHSTANDING VOLTAGE	750 Veff Mini	
INSULATION RESISTANCE	5000 MΩMini	
HERMETIC SEAL	NA Atm.cm ³ /s	
LEAKAGE (pressurized only)	NA	
MECHANICAL DURABILITY	500 Cycles	OTHERS CHARACTERISTICS
WEIGHT	3.7 gr	CABLE RETENTION 110 N Mini
SPECIFICATION		CENTER CONTACT RETENTION
		Axial force - mating end NA N Mini
		Axial force - opposite end 27 N Mini
		Torque NA cm.N Mini
		RECOMMENDED TORQUES
		Mating 100 cm.N
		Panel nut NA cm.N
		Clamp nut NA cm.N

CONNECTOR PARTS	MATERIALS	FINISH (all values are given in micrometers)
BODY	STAINLESS STEEL	GOLD 0.5 OVER NICKEL 2
OUTER CONTACT		
CENTER CONTACT	BRASS	GOLD 1.3 OVER NICKEL 2
INSULATOR	PTFE	-
GASKET	SILICONE RUBBER	-
OTHERS PIECES	STAINLESS STEEL	GOLD 0.5 OVER NICKEL 2

ISSUE	CREATION DATE	FILE PART-NUMBER	 RADIALL ®
0147C00	05/11/1987		

GUILLOMIN

The information given here is subject to change without notice. Design changes may be in order to improve the product.

Connect to the future



R125.072.008

ISSUE **0147C00** SERIES **SMA**

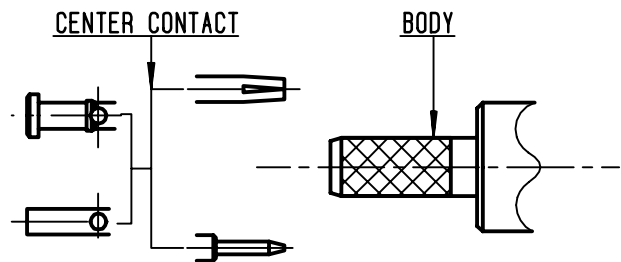
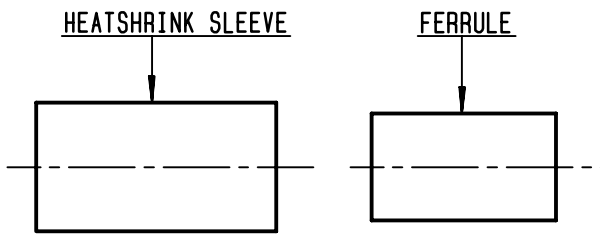

①

Slide ferrule and heatshrink sleeve onto the cable .
Strip the cable .
-
-

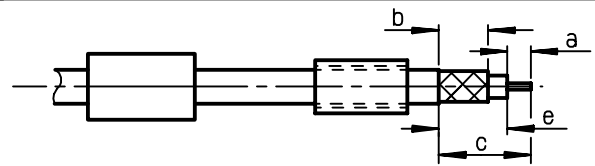

Stripping	a	b	c	d	e
inch	0.079	0.276	0.354	0	0
mm	2	7	9		

②

Slide center contact on until it bottoms against cable dielectric .
Solder center contact .
Clean soldered area .
-
-

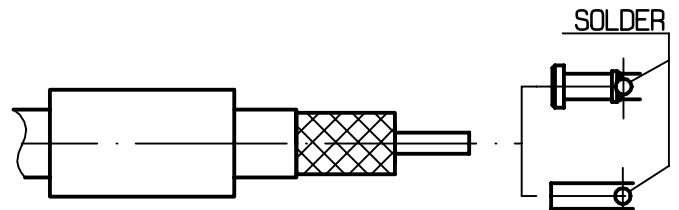

③

Fan the braid .
Slide cable into body until it bottoms against insulator .
Slide ferrule over the braid .
(In direction F)

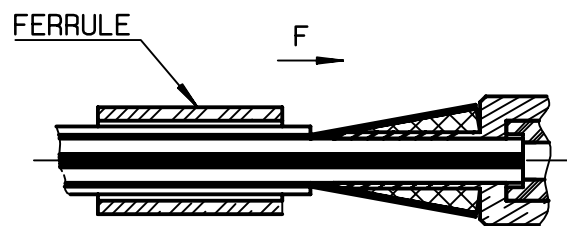

④

Crimp the ferrule with crimping tool R 282 271 000 (Hex. : 0.151) or crimping tool R 282 293 000 (M22520/5-01) and dies R 282 235 037 (M22520/5-037)
Cut the excess braid if necessary .
Slide sleeve over ferrule and heatshrink in place .
-
-

Shrink the heatshrink sleeve

